



Z1000 Z750
RU27226 (03-06) RU27227 (04)
FENDER ELIMINATOR

We at Rumble CONCEPT encourage all installations to be performed by a professional. If you choose to install this product, please read all instructions and take all appropriate safety measures to ensure the proper and safe installation of your new fender eliminator.

Before installation:
our fender eliminator have been designed for modification purposes, we are not responsible for the use or misuse of any products, or verification of the local department of motor vehicles.

The kit include:

- 1 Fender Eliminator bracket
- 4 Allen Screws
- 4 Nuts
- 1 Licence plate light (Already installed on the bracket)

Tools needed:

- Phillips screwdriver
- Cutters
- 10mm box
- 4mm Allen Key

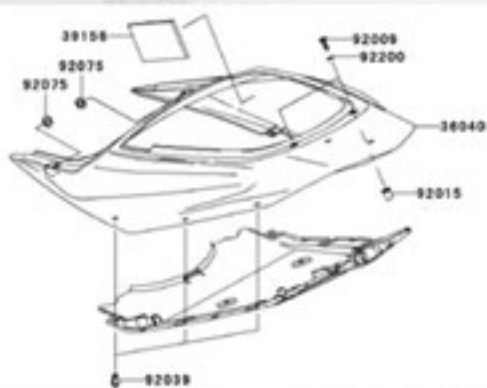
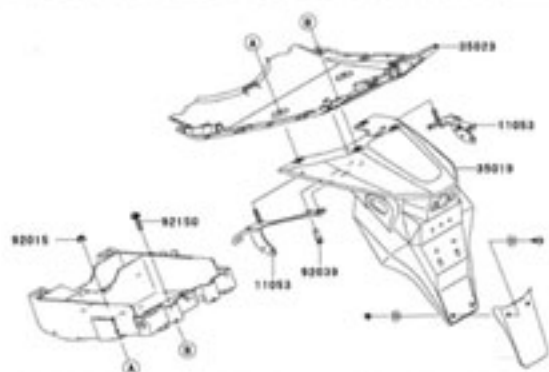

1. Remove the cover or the rear seat..
2. Remove the 6 rivets #92039 under the rear fender, just push on the center of the rivet.
3. Remove the 2 phillips screws #92009 on top of the rear fender.
4. Remove the stock undertail and unplug the wires of flashers and licence plate light.
- 5- Remove the stock flap. You'll need to unscrew the 2 nuts #92015 and the 2 10mm screws #92150. They are located under the seat.



6. Pass the wires of the Fender Eliminator through the stock undertail and plug the flashers and the licence plate light.



7. Install the undertail on the bike with the 6 stock rivets #92039.

8. Put back the 2 phillips screws #92009 on top of the rear fender.

9. Screw the Fender Eliminator on the bike with the Allen screw and the nuts provided with the kit.

10. Put back the cover or your rear seat.

11- Install the licence plate on the bike.



***For further assistance or information, we may be reached at info@rumbleconcept.com.*

***After any installations or modifications, the fender eliminator not returnable. We are not responsible for any damages to the part during the installation process, or to the bike (including the stock undertail part).*